



Project:	
Type:	
Catalog #:	

Model WP36.5-IND Large Induction Wall Pack

HOUSING

- Heavy duty die cast aluminum housing w/ powder coated bronze finish
- Corrosion resistant housing and hardware
- OxyShield 9-stage anti-oxidation process
- Silicone rubber gasket
- 1/2" coin plugs with O-rings for conduit and photocell

ELECTRICAL

- 120V
- 277V

OPTICAL SYSTEM

- Aluminum reflector
- Hinged, high impact, heat resistant borosilicate molded glass lens
- 40W, 80W and 100W Induction
- 5000K

MOUNTING

- Template cast for mounting over 4" recessed box or use 1/2" surface conduit

CODE COMPLIANCE

- CSA Listed for Wet Location
- Meets UL requirements

WARRANTY

- 10 year warranty



WP36.5-INDUCTION

DIMENSIONS

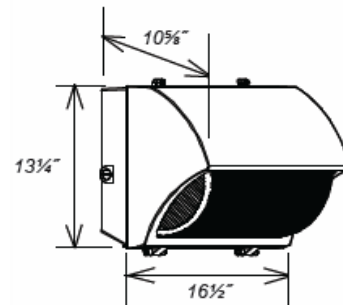

ORDERING INFORMATION

MODEL	WATTAGE	VOTAGE	OPTIONS
WP36.5	40l	120V	PC1 - 120V Photocell
	80l	277V	PC2 - 277V Photocell
	100l		WG - Wire Guard CC - Custom Color

MODEL	WATTAGE	VOLTAGE	OPTIONS
-------	---------	---------	---------

Specifications and dimensions subject to change without notice.