



Project:	
Type:	
Catalog #:	

Model WP35

Large Deep Semi Cutoff Wall Pack

HOUSING

- Heavy duty die cast aluminum housing and hinged front frame w/ powdercoat bronze finish
- Corrosion resistant housing and hardware
- OxyShield 9-stage anti-oxidation process
- Silicone rubber gasket
- 1/2" coin plugs with O-rings for conduit and photocell

ELECTRICAL

- Quad Tap (QT) - 120/208/240/277V

OPTICAL SYSTEM

- Anodized aluminum reflector
- Tempered clear glass lens
- KV pulse rated mogul base socket with nickel plated screw shell



WATTAGE

- HPS: 100 - 400W
- PS: 100 - 400W
- CFL: 1 X 26W, 32W and 42W
2 X 26W, 32W and 42W

MOUNTING

- Cast-in template mounts directly over 4" recessed outlet box or use 1/2" surface conduit

CODE COMPLIANCE

- CSA Listed for Wet Location
- Meets UL requirements

WARRANTY

- 1 year warranty

DIMENSIONS

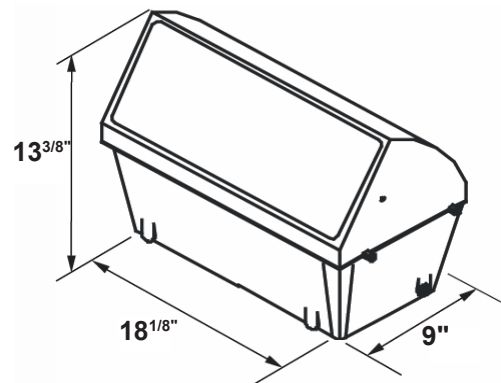

ORDERING INFORMATION

MODEL	WATTAGE		VOLTAGE		OPTIONS
WP35	100H	100P	1X26CF	QT	PC1 - 120V Photocell
	150H	150P	1X32CF		PC2 - 208-277V Photocell
	250H	250P	1X42CF		QRS - Quartz Restrike
	400H	320P	2X26CF		CC - Custom Color
		350P	2X32CF		
	400P	2X42CF			

MODEL	WATTAGE	VOLTAGE	OPTIONS
-------	---------	---------	---------

Specifications and dimensions subject to change without notice.