



Project:	
Type:	
Catalog #:	

Model PS-Series Mini Emergency Power System

HOUSING

- Heavy duty steel cabinet is finished in cream baked-on powder paint providing scratch and corrosion resistance

OPERATION

- Designed to operate fluorescent and incandescent fixtures up to 250 watts
- To determine LED compatibility, contact factory with maximum input current and operating voltage
- Light output maintained at 91% of rated lamp lumens for 90 minutes

ELECTRICAL

- Universal Input: 120/277VAC operation
- Momentary test switch and LED AC-On indicator light
- Load Transfer: All models utilize mechanical relays for load transfer and provide fused AC output load connections
- Charger Type: All units feature a fully automatic, temperature compensating, variable rate float charger
- DC Overload and Short Circuit Protection: Provided by a disconnect circuit that automatically resets itself when the fault condition is corrected
- Automatic Low Voltage Battery Disconnect (LVD)
- AC Lockout: Prevents battery discharge prior to initial unit power-up saving installation time
- Automatic Brownout Protection
- Unit can be located up to 1000 feet from fixtures

BATTERY

- Maintenance-free lead calcium battery
- Recharge Duty Cycle: 24 hours

CODE COMPLIANCE

- UL924 Listed
- Meets NFPA 101 Life Safety Code, NEC, OSHA, Local and State Codes

WARRANTY

- 5 year warranty

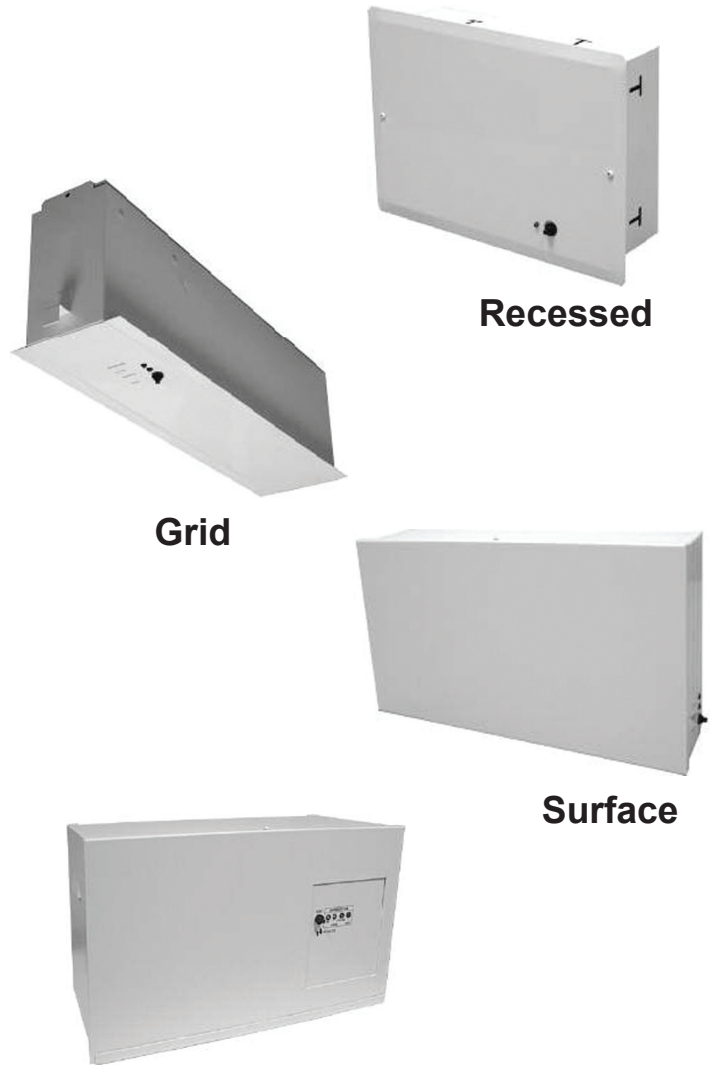

Recessed

Grid

Surface

PS-250S

ORDERING INFORMATION

MODEL	WATTS	MOUNTING	OPTIONS
PS	18	G - Grid	RTS - Remote Test Switch
	32	R - Recessed	TD120 - 120VAC 15 Minute Time Delay
	100	S - Surface*	TD277 - 277VAC 15 Minute Time Delay
	250*		SD - Self Diagnostics (100W & 250W Only)
		*250 Watt Unit Surface Only	220 - 220VAC 50Hz, Input

MODEL	WATTS	MOUNTING	OPTIONS
-	-	-	-

Specifications and dimensions subject to change without notice.

PS250 Surface Models

Surface Models

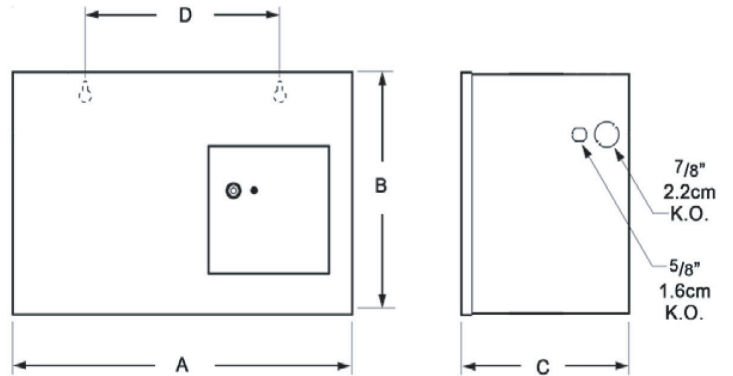
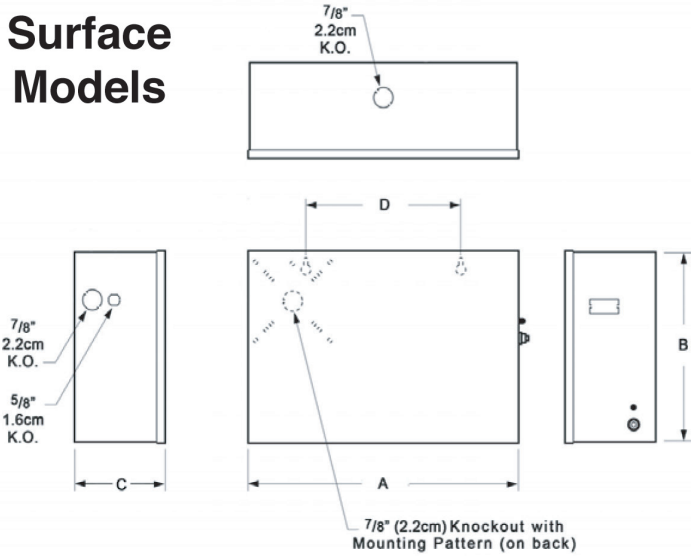

Surface Model	A	B	C	D
PS18 & PS32	12 5/16"	8 1/8"	4 1/8"	7"
PS-100	18 5/8"	9 5/8"	4 3/8"	14 1/2"
PS-250	18 5/8"	10 1/8"	8 1/4"	13"

Recessed Models

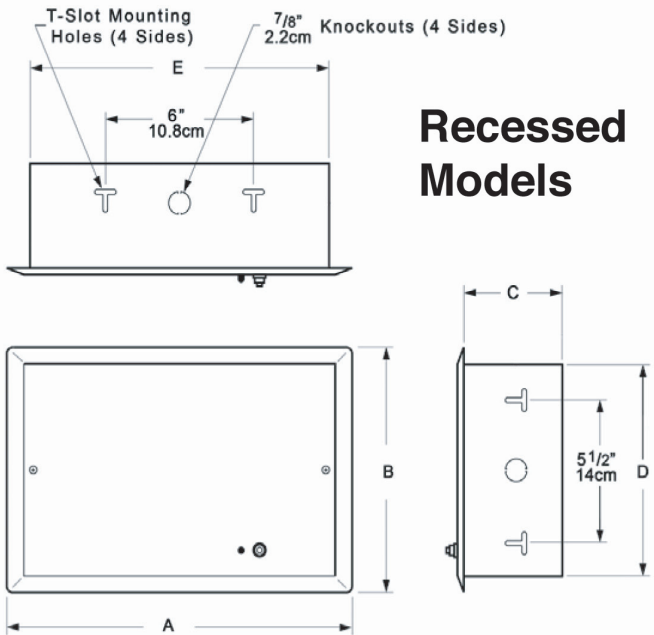

Recessed Model	A	B	C	D	E
PS18 & PS32	14"	9 1/2"	4"	8"	12-1/8"
PS-100	20 1/2"	10 1/2"	4 1/4"	9 1/2"	18 1/2"

Grid Models

