



Project:	
Type:	
Catalog #:	

Model AL6-IND Induction Area Light

HOUSING

- Heavy duty die cast aluminum housing
- Hinged front frame
- Textured architectural bronze powdercoat finish

ELECTRICAL

- Quad Tap (120 - 277V)

OPTICAL SYSTEM

- Specular Type V and Smooth reflectors available
- High-impact, heat-resistant tempered flat glass lens
- 80W or 100W Induction
- 5000K

MOUNTING

- Extruding mounting arms available in 6", 8", 10" and 12"
- Two Piece swivel bracket available
- Adjustable Slipfitter
- Yoke

CODE COMPLIANCE

- CSA Listed for Wet Location
- Meets UL Requirements
- ARRA Compliant

WARRANTY

- 10 year warranty

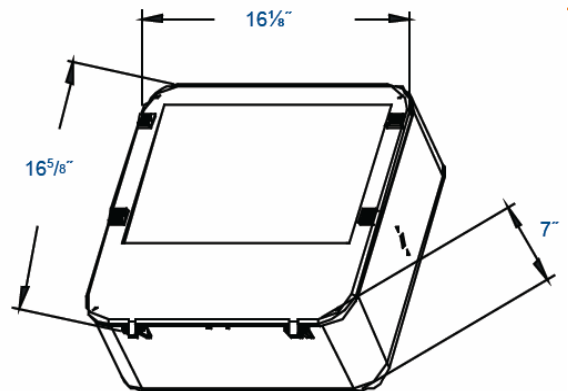

ORDERING INFORMATION

MODEL	WATTAGE	REFLECTOR	VOLTAGE	OPTIONS
AL6	80I 100I	5 - Type V S - Smooth	QT	FLEM6 - 6" Aluminum Mounting Arm * FLEM10 - 10" Aluminum Mounting Arm * FLEM12 - 14" Aluminum Mounting Arm * FLEM18 - 18" Aluminum Mounting Arm * *Specify R for Round Pole SWB - Swivel Bracket SF - Slipfitter Y - Yoke WG - Wireguard

MODEL	WATTAGE	REFLECTOR	VOLTAGE	OPTIONS
-------	---------	-----------	---------	---------

Specifications and dimensions subject to change without notice.